

Discovery™

AGES
8+

INSTRUCTION MANUAL



AA
x2
NOT INCLUDED
1.5V

Do not mix old and new batteries. Do not mix alkaline, standard (carbon-zinc), or rechargeable (ni-cad, ni-mh, etc.) batteries.

900x
Power Microscope
Biological Experiments Gear



WARNING:
CHOKING HAZARD – Small parts.
Not for children under 3 years.



WARNING:
FUNCTIONAL SHARP POINT – Not for children
under 3 years.

CONTENTS

Microscope Parts:

1. Eyepiece
2. Focus Knob
3. Stage
4. Metal Stage Clips
5. Colour Filter Wheel
6. Objective
7. Objective Turret
(5x, 20x, 45x)
8. Illumination On/Off Switch and Mirror
9. Rubber Base and Battery Case
10. Microscope Arm

Additional Contents:

11. (5) Prepared Slides and (7) Blank Slides with Slide Case
12. (8) Slide Covers/Labels
13. (3) Collection Vials
14. Test Tube
15. Petri Dish
16. Tweezers / Scalpel / Pipette / Stirring Rod / Spatula*

CONTENTS



How Do I Use My Microscope

Before you use your microscope, make sure that the table, desk or surface that you place it on is stable and is not subject to vibration. If the microscope needs to be moved, hold it by the arm and base while carefully transferring it. Once the microscope is in a suitable location and the batteries are installed, check the light source to make sure that it illuminates. Use a microfiber cleaning cloth to gently wipe the lenses off. If the stage is dirty with dust or oil, carefully clean it off. Make sure that you only raise and lower the stage using the focus adjustment knob.

How Do I Operate The Illumination?

Locate the mirror/light on the base of the microscope. Flip the mirror/light to the "on" position (with the light facing up) and the light will illuminate. This microscope is equipped with an incandescent light that illuminates the specimen from below. The colour filter wheel is located in the middle of the microscope stage. The filters help you when you observing very bright or clear specimens. Using these filters, you can choose various brightness levels and colours. This helps you better recognize the components of colourless or transparent objects (e.g. sea salt).

How Do I Adjust My Microscope Correctly?

Place the microscope in a suitable location as described above, and sit in a comfortable viewing position. Always start each observation with the lowest magnification. Adjust the distance of the microscope stage so that the stage is in the lowest position — farthest away from the turret head. Turn the objective turret until it clicks into place at the lowest magnification (Objective: 5x/ Magnification: 100x). Note: Before you change the objective setting, always make sure the microscope stage is farthest away from the turret by rotating the focus knob. Separating the stage and turret by rotating the focus knob will avoid causing damage to the specimen slide or microscope. When starting an observation, always start with the 5x objective in the rotating head.

Microscope Parts:

1. Eyepiece
2. Focus Knob
3. Stage
4. Metal Stage Clips
5. Colour Filter Wheel
6. Objective
7. Objective Turret (5x, 20x, 45x)
8. Illumination On/Off Switch and Mirror
9. Rubber Base and Battery Case
10. Microscope Arm

Additional Contents:

11. (5) Prepared Slides and (7) Blank Slides with Slide Case
12. (8) Slide Covers/Labels
13. (3) Collection Vials
14. Test Tube
15. Petri Dish
16. Tweezers / Scalpel / Pipette / Stirring Rod / Spatula*

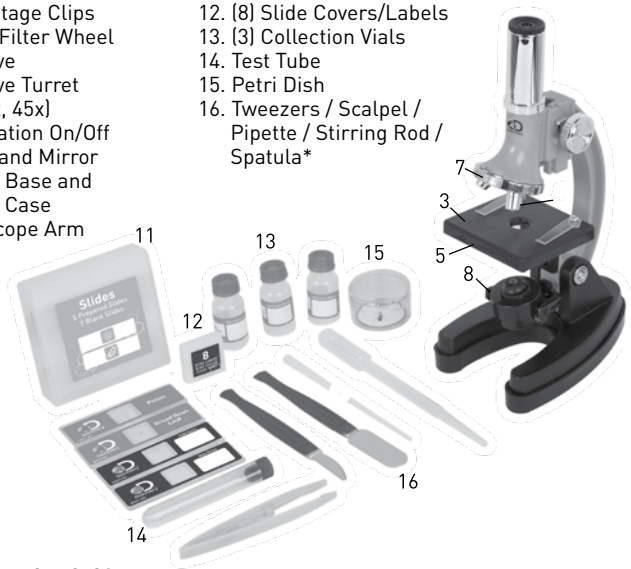

Troubleshooting Guide:

No recognizable image	Turn on light, Readjust focus, Start with the lowest power objective (5x)
No image	Centre object on slide under lowest power objective
No light	Replace batteries, Check on/off position

Did You Know?

The highest magnification is not always the best for every specimen!

How Do I Observe The Specimen?

Sitting in your location with adequate illumination chosen from the colour filter wheel, the following basic rules should be observed. Start with a simple observation at the lowest magnification. Position the object or specimen in the middle of the stage under the stage clips, centred over the lower light. Focus the image by rotating the focus knob until a clear image appears in the eyepiece.

Magnification Guide:

20x	5x	100x
20x	20x	400x
20x	45x	900x

Place the prepared slide directly under the objective on the microscope stage and secure it with the stage clips. The prepared slide should be located directly over the lower illumination. Look through the eyepiece and carefully turn the focus knob until the image appears clear and sharp. Now you can select a higher magnification by rotating to the 15x/300x objective turret. Higher levels of magnification can be achieved by turning the objective turret to a higher setting (300x or 900x). Following this procedure creates a steady increase of magnification without overpowering the view of the object. The following magnification order should be used: 100x, 300x then 900x. Each time the magnification changes (due to the objective change), the image sharpness must be readjusted with the focus knob. When doing this, be careful because if you move the microscope stage too quickly, the objective and the slide could come into contact and cause damage to the slide or microscope.

For transparent objects (e.g. sea salt), light is projected by the lower light traveling from below the stage, through the objective and eyepiece, and finally into your eye. This process of light transmission is known as microscopy. Many micro-organisms found in water, plant components and the smallest animal parts are transparent in nature. Opaque specimens, on the other hand, will need to be prepared for viewing. Opaque specimens can be made transparent by a process of treatment and penetration with the correct materials (media), or by slicing. You can read more about creating specimens in the enclosed microscope experiments booklet.

SAFETY WARNINGS

Read and follow the instructions, safety rules, and first aid information.

- This microscope set is intended for children older than age 8. Children should only use this device under adult supervision. Never leave a child unsupervised with this device. Accessories in the experiment kit may have sharp edges and tips. Please store the device and all of its accessories and aids out of the reach of young children when not being used due to a risk of injury.
 - Chemicals: Any chemicals and liquids used in conjunction with the device should be kept out of reach of children. Do not drink any of the chemicals contained in this set. Hands should be washed thoroughly under running water after working with these chemicals. In case of accidental contact with eyes or mouth, rinse the affected area with water. Seek medical treatment for ailments arising from contact with the chemical substance, and take the chemicals with you to the doctor.
 - Choking hazard: Children should only use device under adult supervision. Keep packaging materials like plastic bags and rubber bands out of the reach of children as these materials pose a choking hazard.
 - Battery guidelines: This device contains electronic components that are powered by batteries. Batteries should be kept out of children's reach. When inserting batteries, please ensure the polarity is correct. Insert the batteries according to the displayed +/- information. Never mix old and new batteries. Replace all batteries at the same time. Never mix alkaline, standard carbon-zinc and rechargeable nickel-cadmium batteries. Never short circuit the device or batteries or throw either into a fire. Leaking or damaged batteries can cause injury if they come into contact with the skin. If you need to handle such batteries, please wear suitable safety gloves. Remove batteries from the product before extended storage to prevent leaking.
- Do not immerse the battery compartment in water.
- Risk of fire: Do not place device, particularly the lenses, in direct sunlight. The concentration of light rays could cause a fire.
 - Do not disassemble this device. In the event of a defect, please contact your dealer. The dealer will contact the Customer Service Department and can send the device in to be repaired if necessary.
 - Do not subject the device to temperatures exceeding 60° C (140° F).



- Disposal: Keep packaging materials, like plastic bags and rubber bands, away from children as they pose a risk of suffocation. Dispose of packaging materials as legally required. Consult the local authority on the matter if necessary and recycle materials when possible.



©2017 Discovery Communications, LLC. Discovery™ and the Discovery™ logo are trademarks of Discovery Communications, LLC, used under license.
All rights reserved. discoverykids.com

©2017 Explore Scientific, LLC, a Journey North Company.
1010 S. 48th Street, Springdale AR 72762
All rights reserved. explorescientificusa.com | exploreone.com | 866.252.3811
Made in China

CONFORMS TO THE SAFETY REQUIREMENTS OF ASTM F963

